

# CanadaDocks™

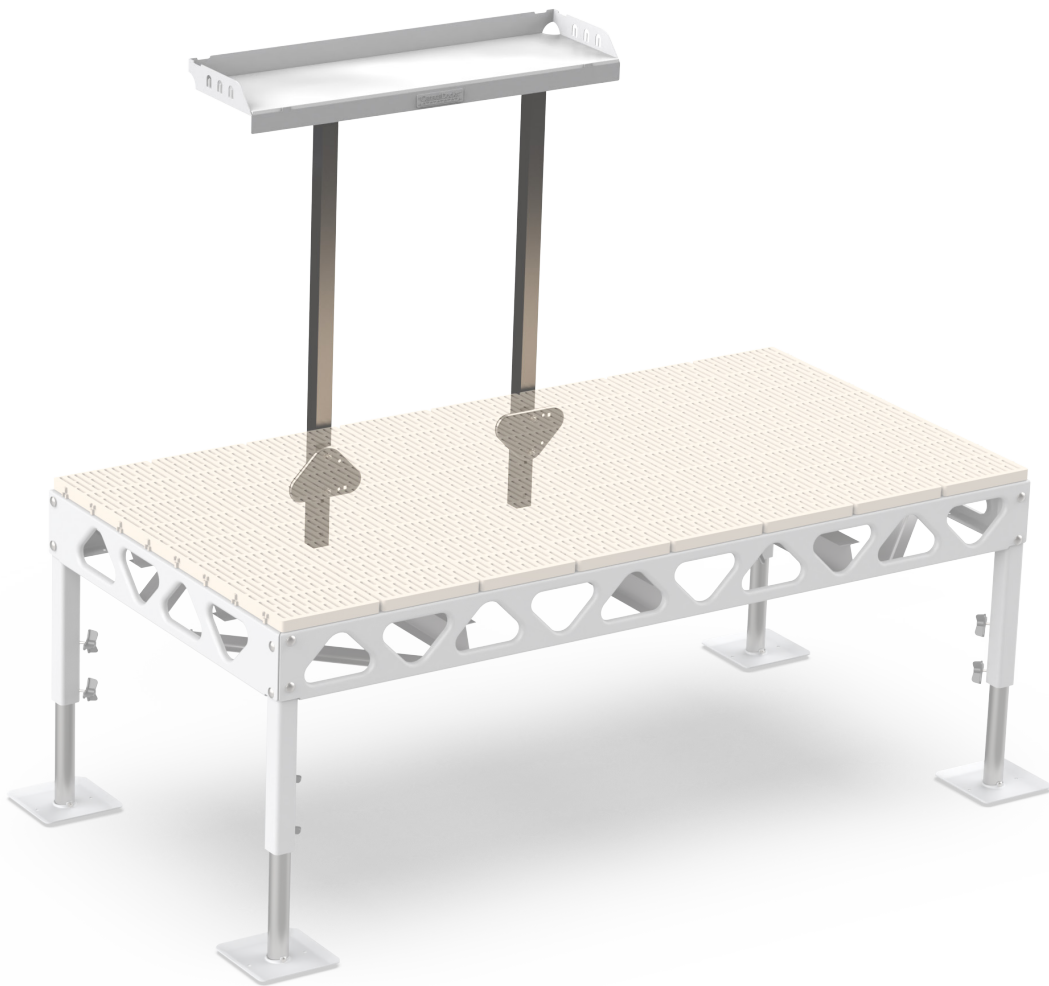

Where *fun* on the water *begins!*



## Docksider Fillet Table

Read this manual and related assembly instructions before attempting to assemble the parts enclosed to ensure that your new CanadaDocks System is assembled safely and correctly.

## INCLUDED IN KIT:

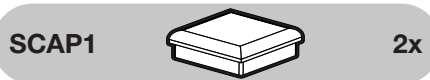
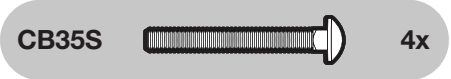
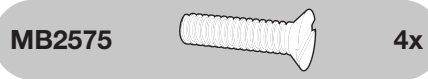
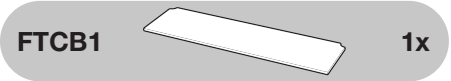
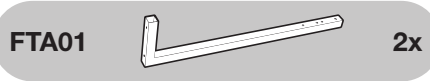
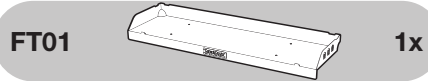

## Tools Required:

9/16" SOCKET WITH RATCHET TO  
SUIT OR 9/16" WRENCH

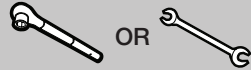

Phillips Screwdriver  
Flat Head



1

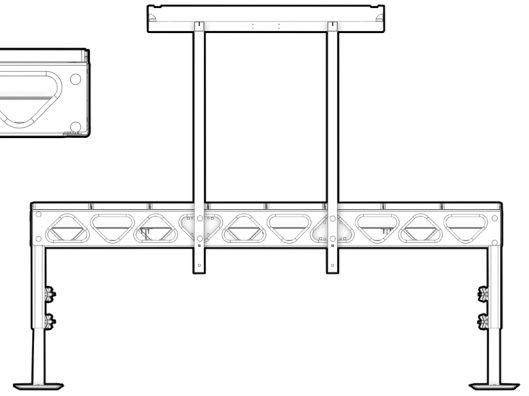
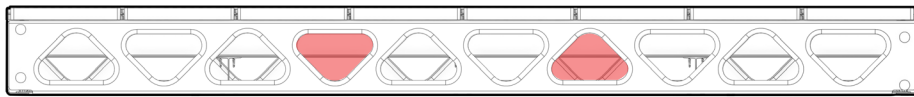

Determine where you would like to install your Dockside Fillet table.

**PLEASE NOTE:** Locations must include 4 triangles, with 2 inbetween bracket plate locations.

2

TPU1



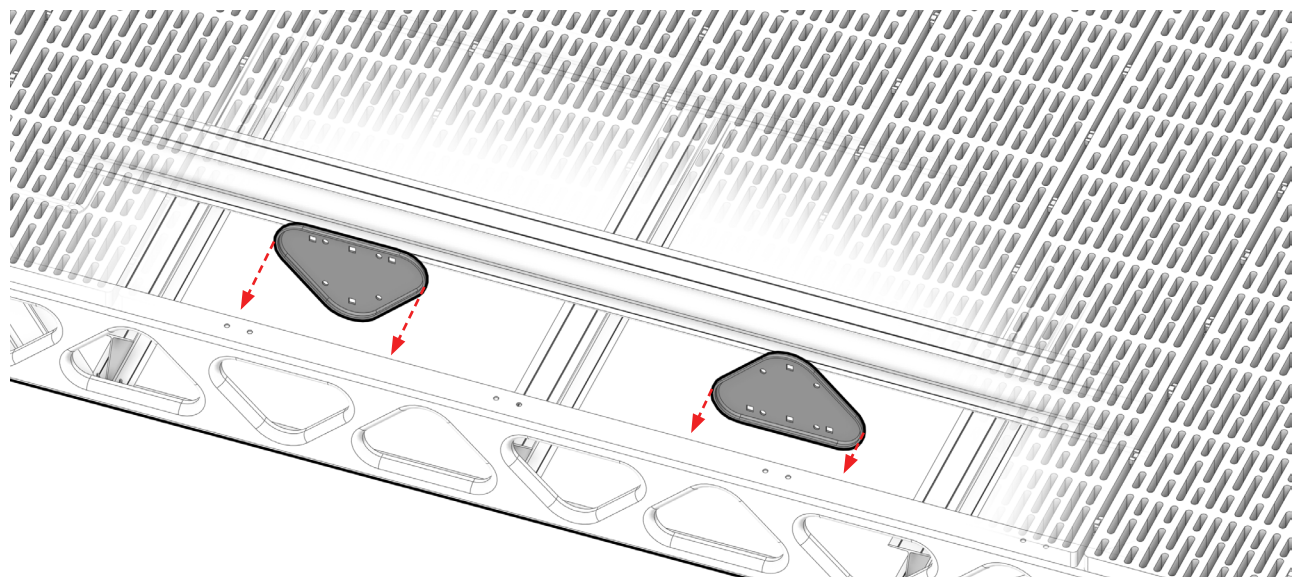

2x

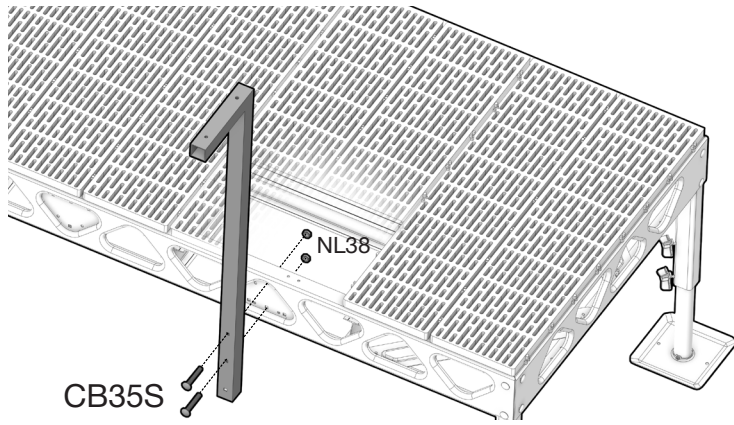

Place triangle backing plates (TPU1) in the chosen locations from **STEP 1**.

3

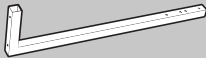

- FTA01  2x
- CB35S  4x
- NL38  4x

Install arms in the triangle backing plates (**TPU1**) using the provided hardware. Repeat for the 2nd backing plate from **STEP 2**.

**PLEASE NOTE:** Ensure the arms are installed in the correct orientation as seen above and hardware is tightened.

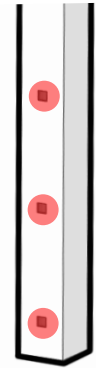

4

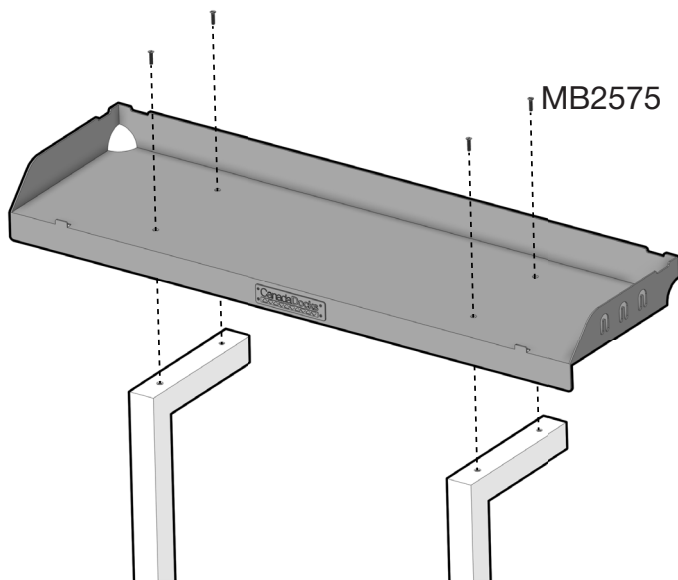

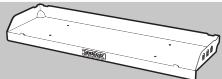
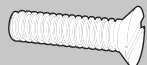
- FT01  1x
- MB2575  4x

Install the table top (**FT01**) onto the arms (**FTA01**) by inserting the bolts in the threaded holes as seen to the side.

**PLEASE NOTE:** Ensure the front of the table top is facing the inside of the dock.

5

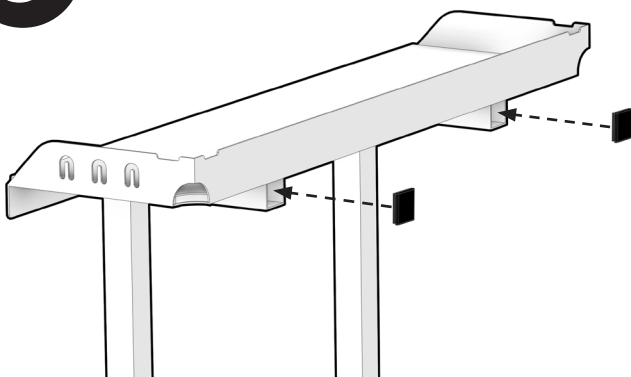

Insert Caps (**SCAP1**).

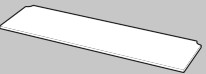
- SCAP1  2x
- FTCB1  1x

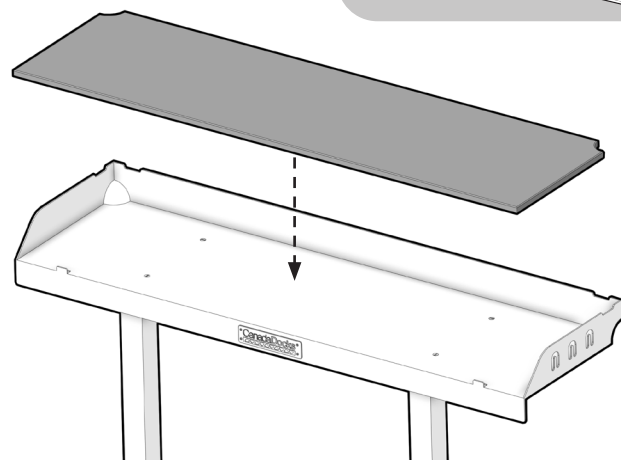

Place the cutting board down (**FTCB1**) into the table top.

# Where *fun* on the water *begins!*

Please leave us a **Google review**



We'd love to hear from you and see your photos!



**Phone**

705.434.0359

1.877.434.0359



**Email**

info@canadadocks.ca



**Address**

3690 Adjala-Tecumseth Tl,

Beeton ON L0G 1A0

Rev 01 12.12.24

**CanadaDocks.ca**

